



CS Series

CS-8CFT



Specifications

Type	Coaxial Ceiling Speaker with Transformer
Power Capacity	80 Watt
Sensitivity (1W@1M)	92 dB
Frequency Response	65Hz - 20kHz
Dimension (W x D)	Ø 272mm(10.71") x 101mm(3.98")
LH Component	8" (203mm) Cone Speaker
HF Component	1" (25.4mm) PEI Diaphragm
Transformer Input Rate	6W , 12W , 25W
Baffle Cutout Dimension	Ø 241mm (9.49)"
Net Weight	1.4 kg (3.08 lbs)
Shipping Weight (2 pcs)	3.4 kg (7.48 lbs)

Applications

CS-8CFT

The CS-8CFT is a high output coaxial ceiling loudspeaker designed for medium to high ceiling applications. The two way design features an 8 inch (203mm) diameter woofer and a coaxially mounted high frequency transducer. The overall outside diameter of the system is 10.7 inches (272mm). This combination of low frequency and high frequency transducers provides broad frequency response with a low frequency limit of 65Hz. The high frequency response extends to beyond 20kHz, making the CS-8CFT ideal for reproduction of wide band high fidelity signals.

The system features a full bandwidth low distortion line matching (constant voltage) transformer with power taps of 25 watts, 12 watts, and 6 watts. This combination of tap values insures a high degree on installation flexibility in terms of matching acoustic levels to spaces.

The CS-8CFT features a full 80 watts of program power handling capacity. This power handling capacity, coupled with P Audio's reputation for high reliability, make the CS-8CFT and excellent system for restaurant, pub, retail spaces and office ceiling systems.

The CS-8CFT has an integral mounting system that provides easy and quick system installation.

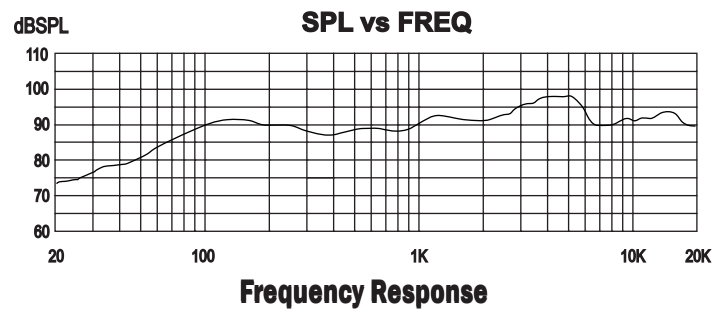
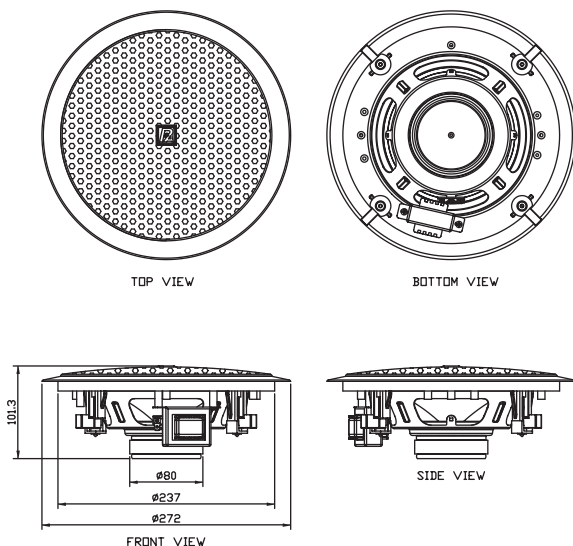

19/4 Moo 2 T.Bangkratuk A. Samparn Nakornpathom 73210 Thailand
 Tel: +66-2-441-6600 Auto 30 Lines
 e-mail: info@paudiothailand.com
 Web site: www.paudiothailand.com
 All rights reserved by P.Audio System Co., Ltd. 2007

